

LEG/PAD DETAIL

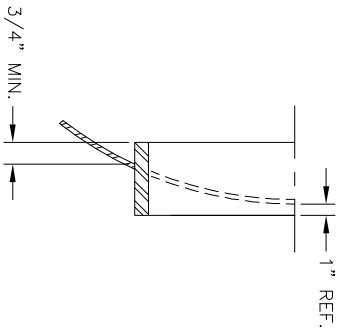

MANWAY DETAIL

NO. QTY	DESCRIPTION	SPEC	SUB-DWG.
S1 1			
H1 2			
M1 1	12" X 16" X 3/4" X 4" 300# MANWAY	SA-106-C	
F1 3	3"-NPT 1500# RADIAL FLANGE	SA-181-70	
F2 1	3"-NPT 1500# FLAT FLANGE	SA-181-70	
F3 1	2"-NPT 1500# FLAT FLANGE	SA-181-70	
C1 1	1 1/2"-NPT 3000# FULL COUPLING	SA-105	
F4 1	1 1/4"-NPT 1500# RADIAL FLANGE	SA-181-70	
C2 1	3/4"-NPT 3000# FULL COUPLING	SA-105	
F5 2	1/2"-NPT 1500# FLAT FLANGE	SA-181-70	
A1 1	BAFFLE	A84451	
A2 2	1/2" X 4" X 4" LIFT LUG	SA-516-70	A84386
S2 4	1/2" X 5" X 5" PAD	SA-516-70	
S3 4	3/8" X 4" X 4" ANGLE LEG X 29" LONG	SA-36	
NP 1	ASME DATA PLATE	C1010	

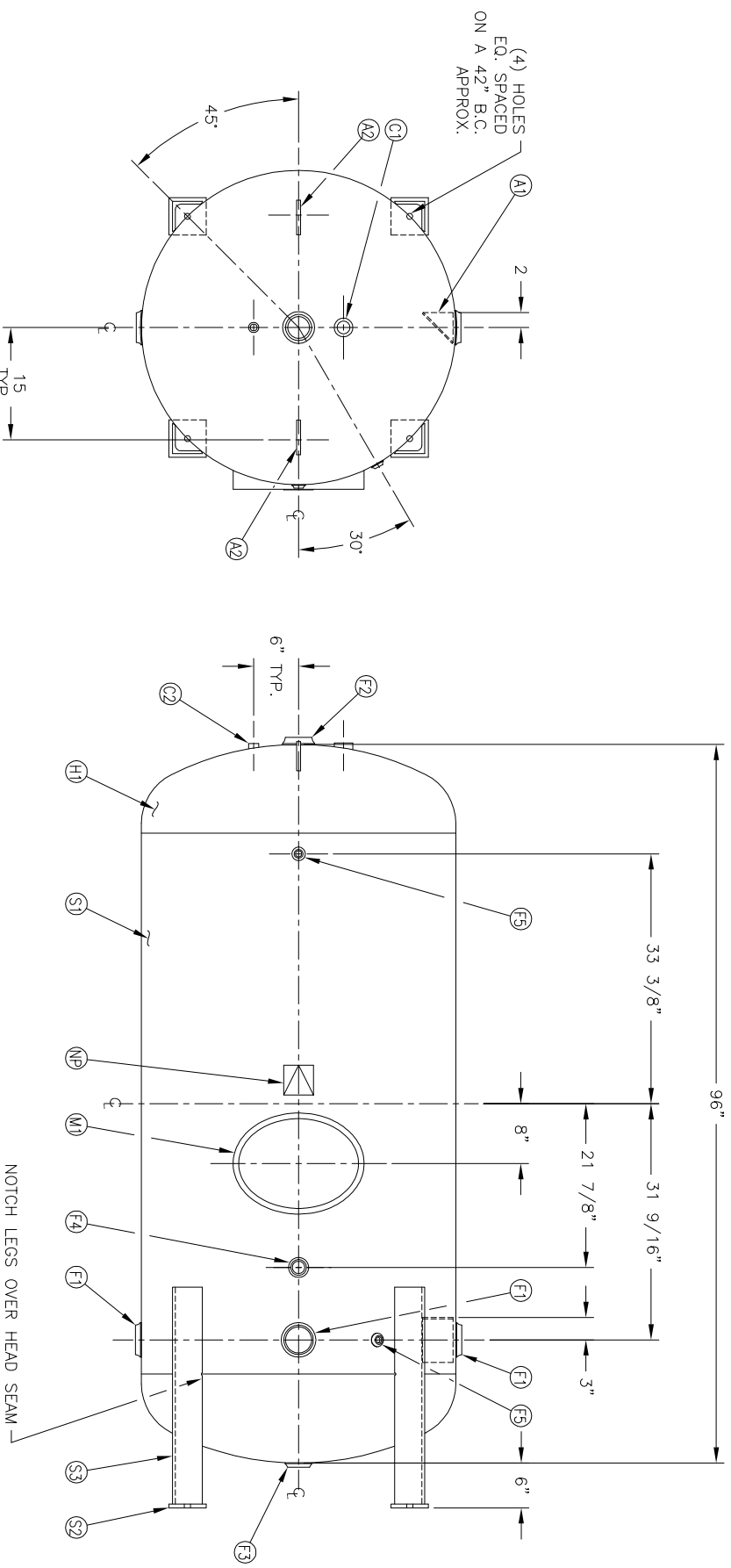

MANWAY DETAIL

LEG/PAD DETAIL

MANWAY DETAIL

SWM DATE	BY	REVISION	APP	REF	REV	NOTES	SPECIFICATIONS
						INTERIOR FINISH NOTE 1. 1/8" RADIUS ALL EDGES. 2. GRIND ALL INTERNAL WELDS SMOOTH. 3. SANDBLAST TO NEAR WHITE FINISH. 4. ALL VOIDS AND GAPS TO BE CAULKED 5. COAT WITH DEVOE 233H EPOXY.	O.D. 42 LGTH. 96 MAMP 150 PSI @ 250 F QAL 535 SA WT. 1225# CUFT. CODE ASME SECT.VIII, DIV.1 PER DATE OF DWG/LAST REV

ALL OPEN TAPS TO HAVE PLASTIC THREAD PROTECTORS

42" X 96" VERT. EPOXY LINED WATER TANK

SCALE: NONE

DRAWING NO. 302520

DATE	BY	DATE	DATE	SCALE	DRAWING NO.
				NONE	302520