

CODE/ADDENDA _____ APPROVED _____
 RELEASED FOR PRODUCTION _____
 Q.C. _____ DATE _____

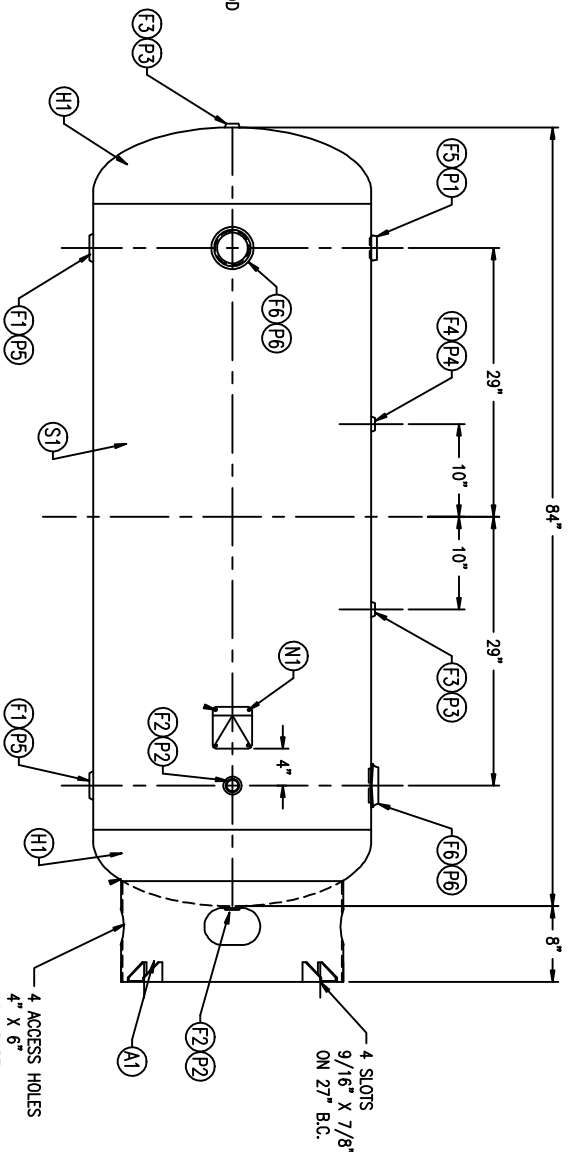
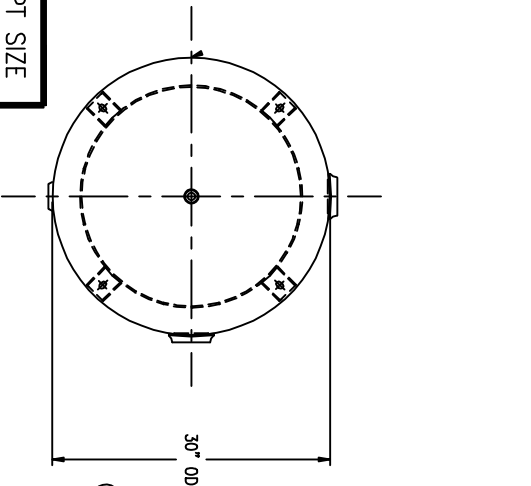

FIND NO.	NPT SIZE
F1	2
F2	1
F3	1/2
F4	1/4
F5	1 1/2
F6	3

SYM	DATE	BY	REVISION

APP

NOTES

SPECIFICATIONS

O.D.: 30 LGTH: 84
 MAMP: 300 PSI @ 400° F

GAL: 240 SA: 59
 WGT: 850 # CUFT: 31.1
 CODE: ASME / NB
 PER DATE OF DWG/LAST REV

CRN# F1629.123456

WELD DETAILS M-1932
 STD. TOLERANCES (UNLESS OTHERWISE NOTED) M-2461



VERTICAL AIR RECEIVER
 240 GALLON

DRAWN BY	DATE	SCALE: NONE
APP. BY	DATE	DRAWING NO. 302429